

52 LIMPIAPARABRISAS

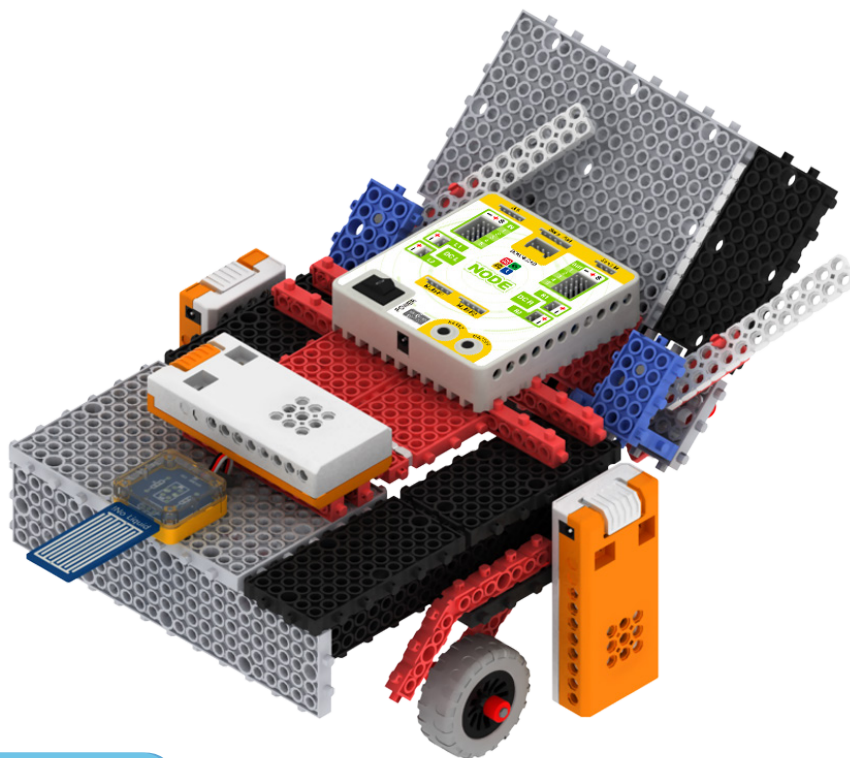

Piezas

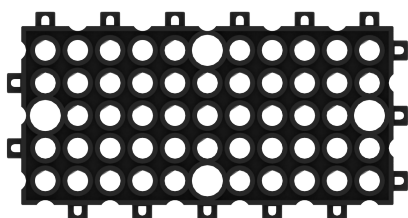

Bloque 5x11 (4)

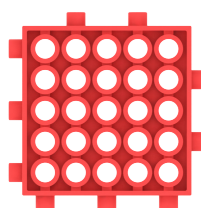

Bloque 5x5 (2)

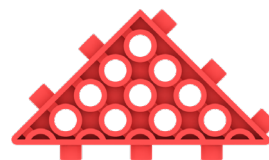

Bloque triangular (2)

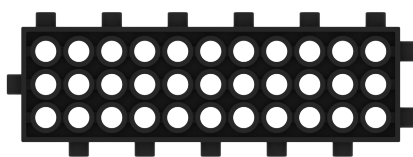

Bloque 3x11 (2)

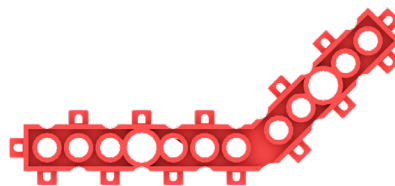

Bloque 45° (4)

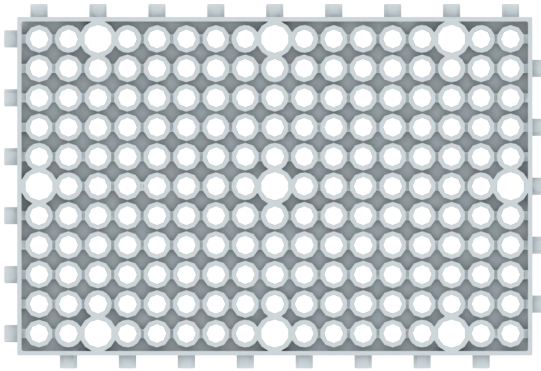

Bloque 11x17 (2)

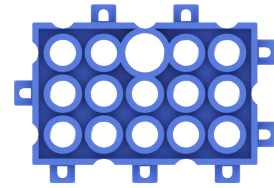

Bloque 3x5 (4)



Bloque de unión 2 (2)

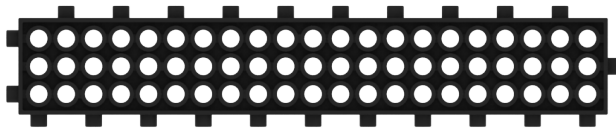

Bloque 3x21 (2)

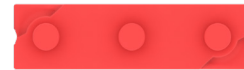

Bloque de unión 1 (2)

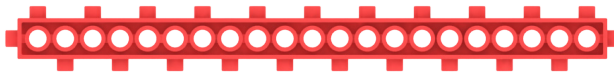

Bloque 1x21 (2)



Bloque con eje (4)

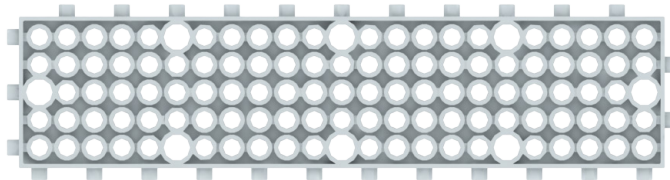

Bloque 5x23 (2)

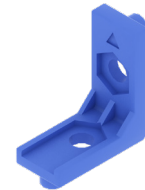

Adaptador L (4)



Bloque N 1x9 (1)



Bloque N 1x11 (3)



Bloque N 2x13 (2)

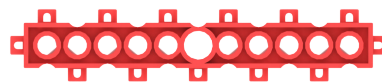

Bloque 1x11 (3)



Conector de eje (1)



M-shaft

Eje M (4)



Goma de eje roja (7)



Remache doble (1)

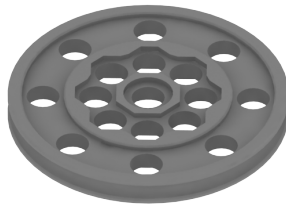

Llanta 2 (2)



Rueda M (2)



Motor 2 (1)

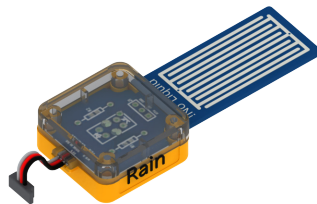

Sensor de lluvia (1)



Cable de conexión (3)



Alargador de cable (1)

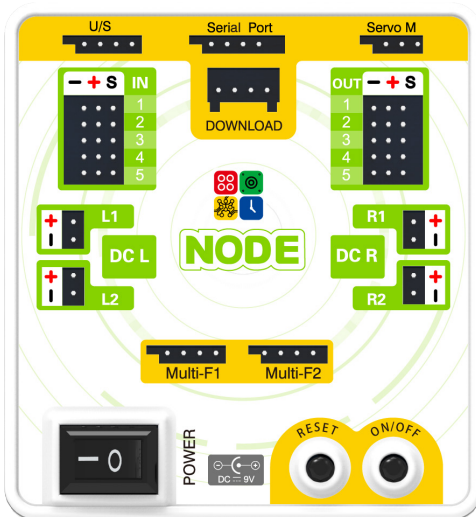

Placa base NODE (1)



Portapilas o portabaterías 1 (1)

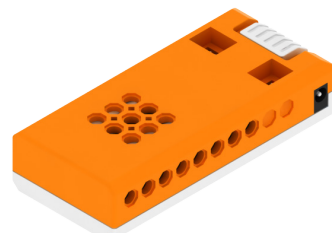

Portapilas o portabaterías 2 (2)

01

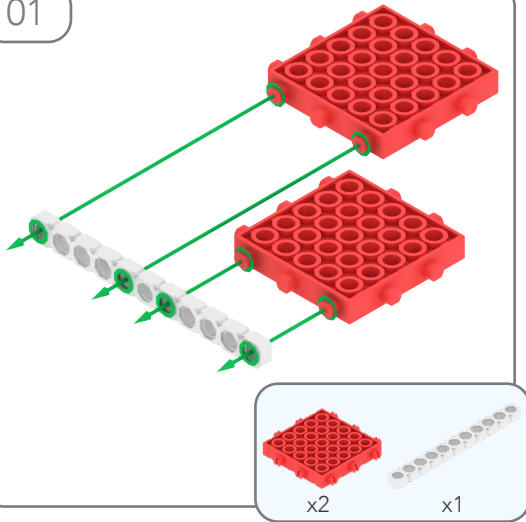

02

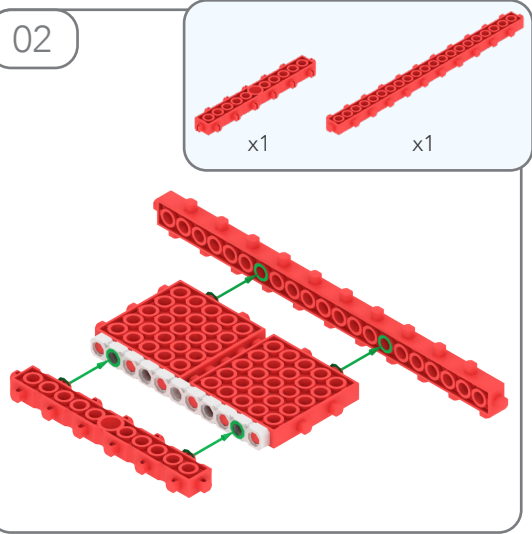

03

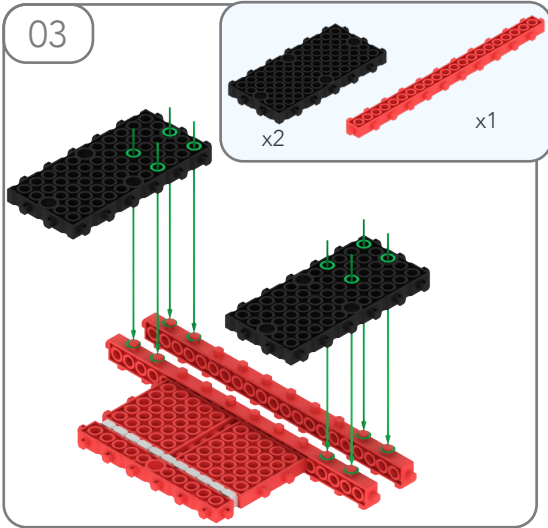

04

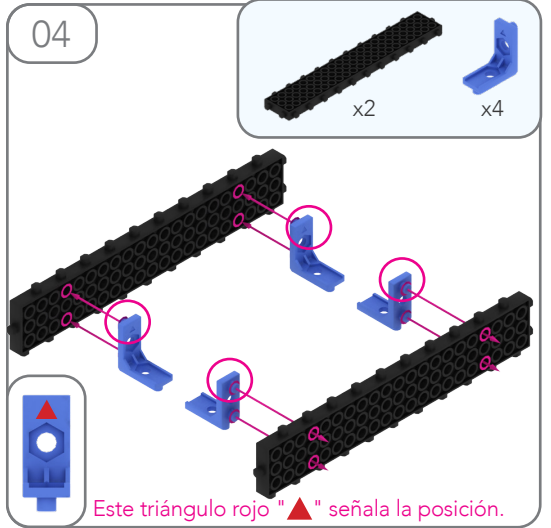

05

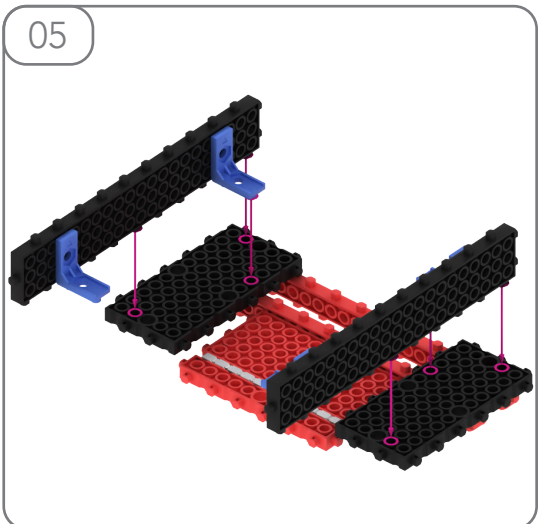

06

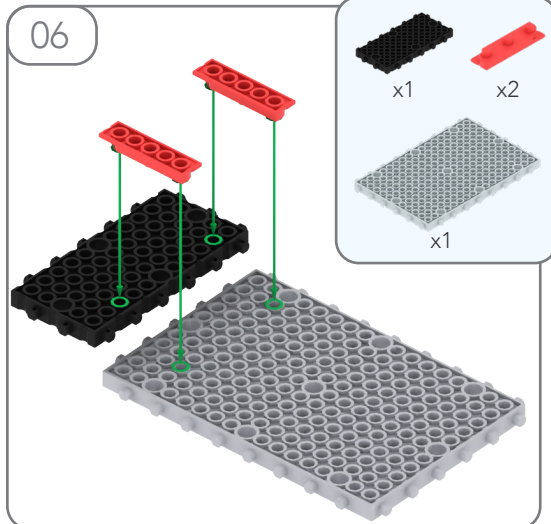

07

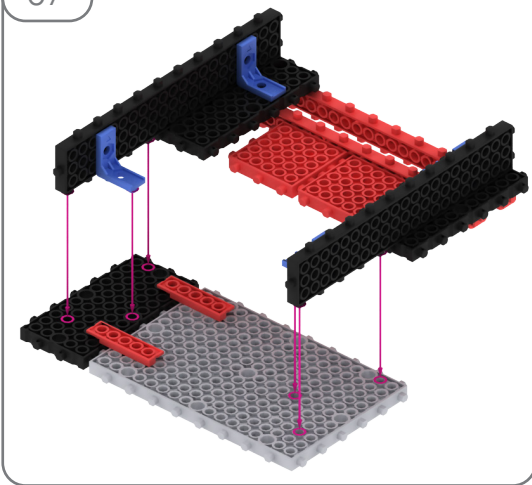

08

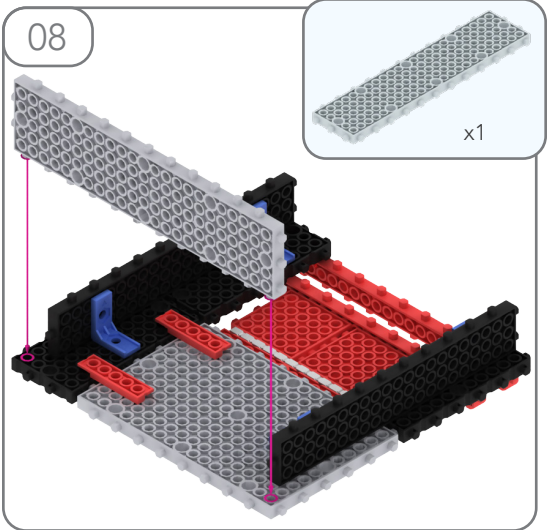

09

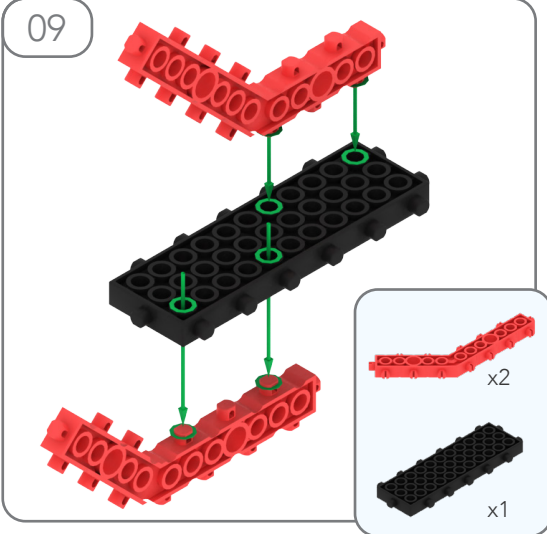

10

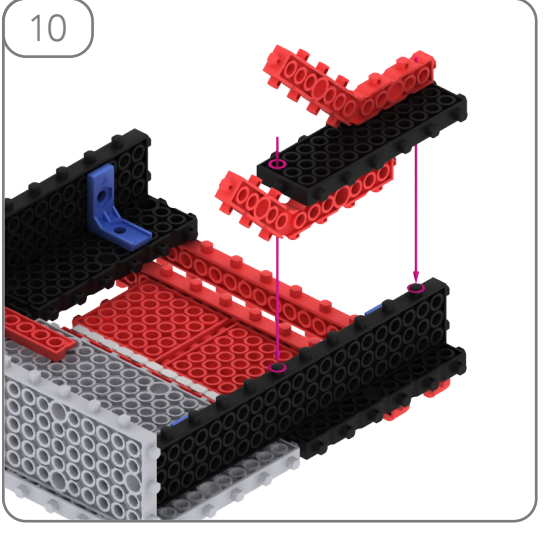

11

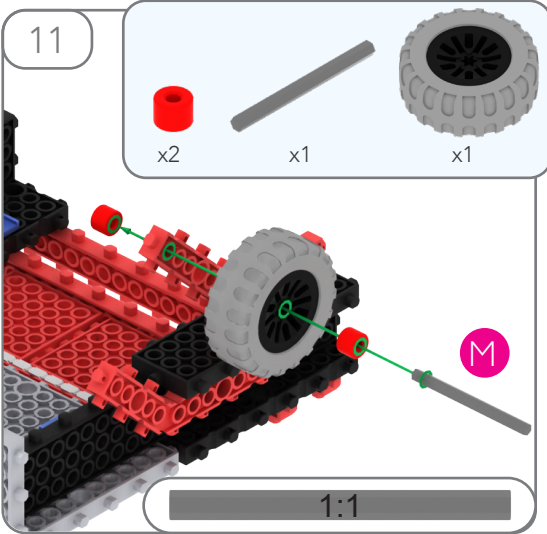

12

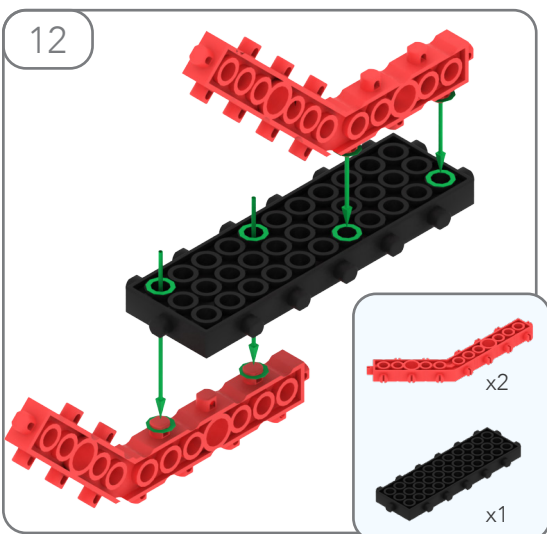

13

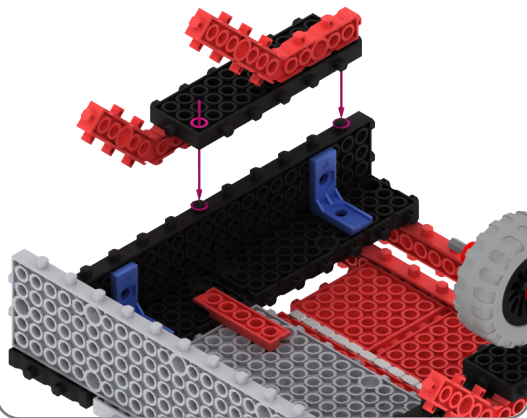

14

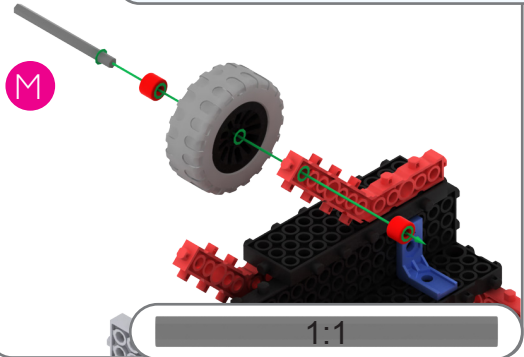
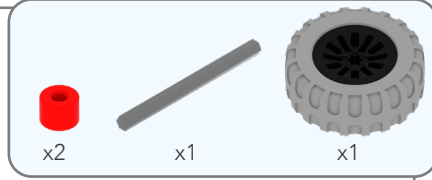

15

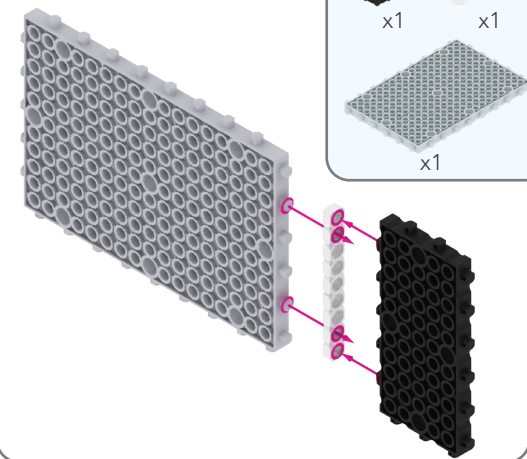
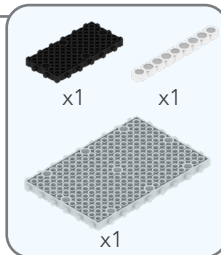

16

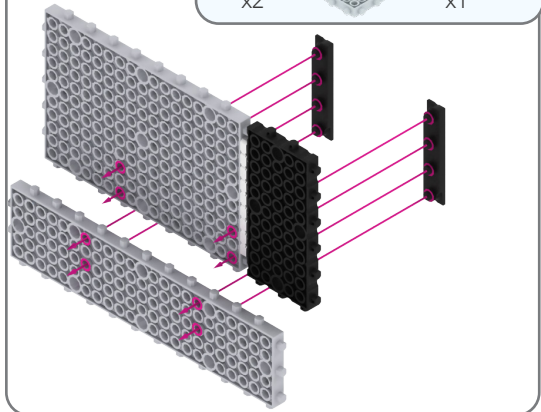
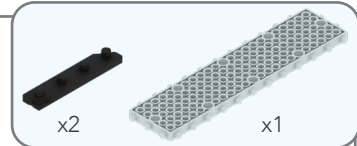

17

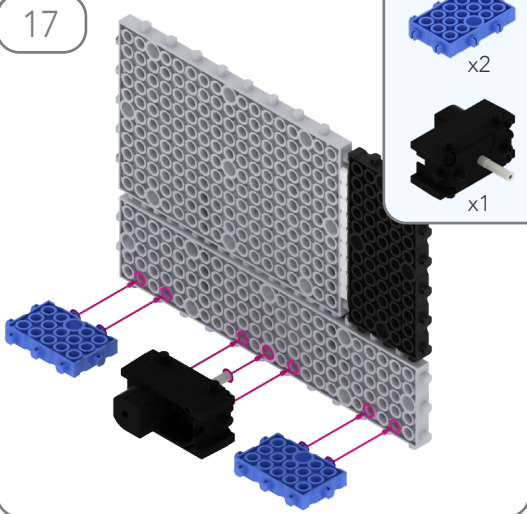
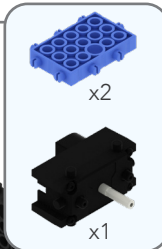

18

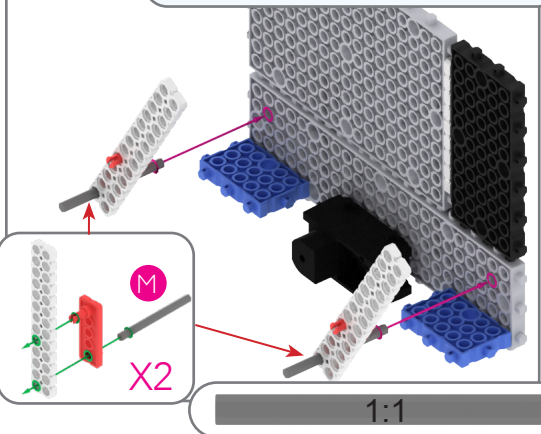
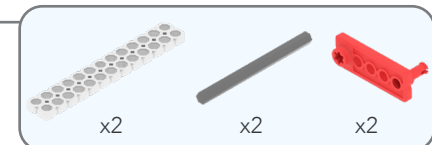

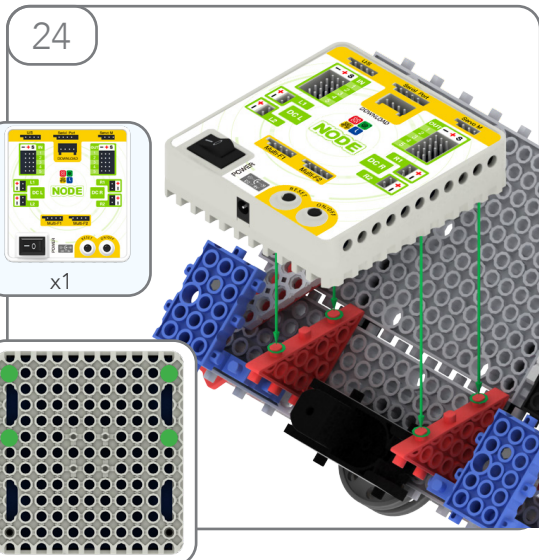
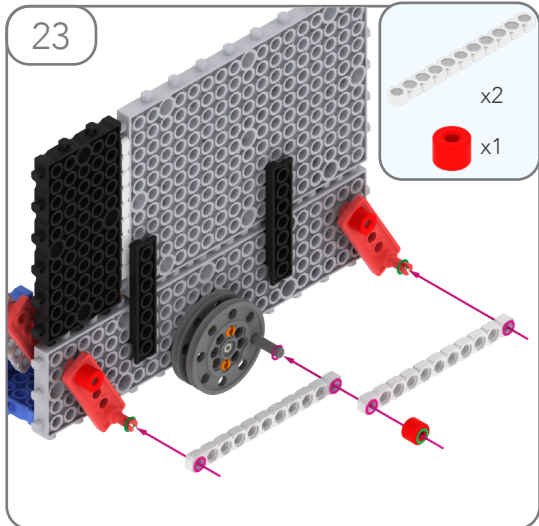
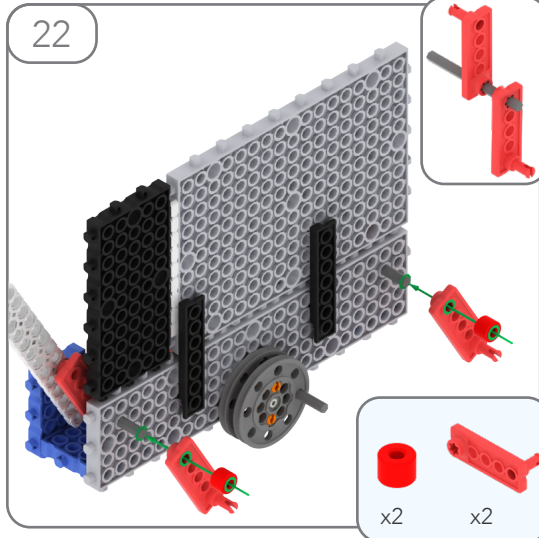
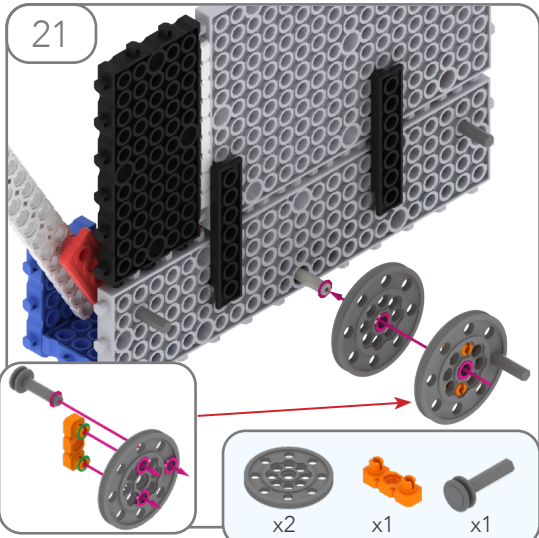
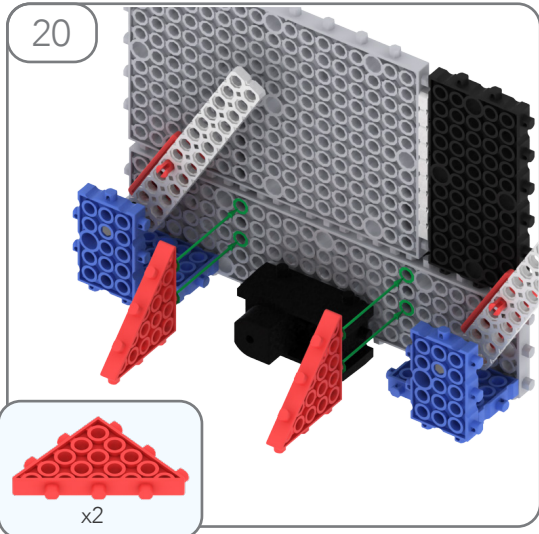
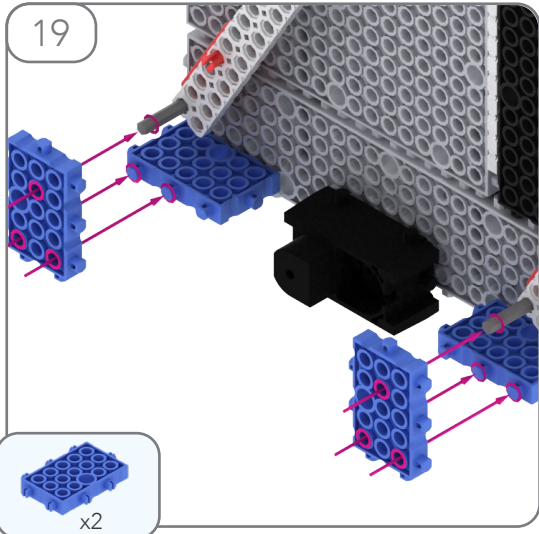

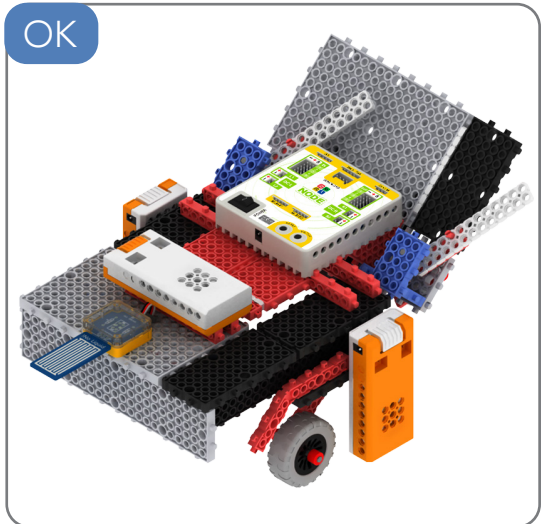
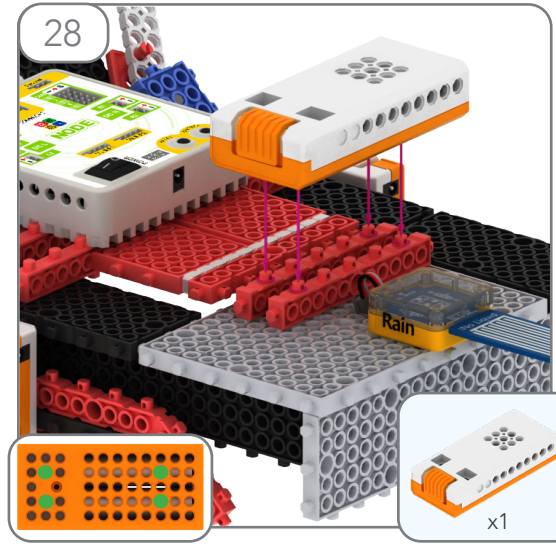
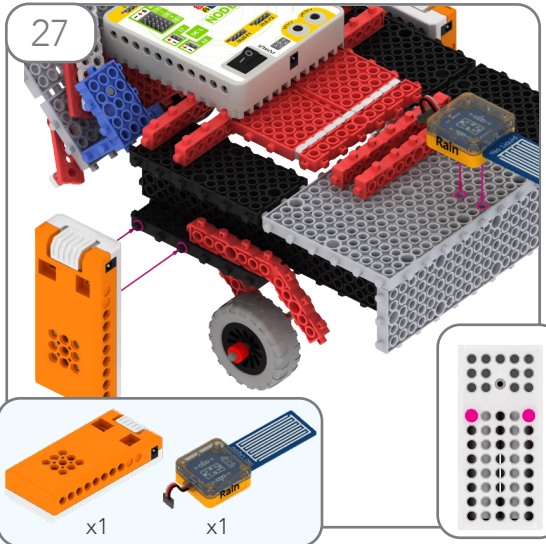
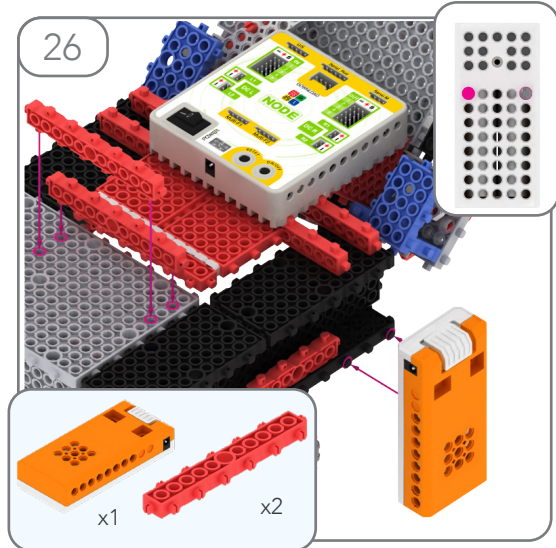
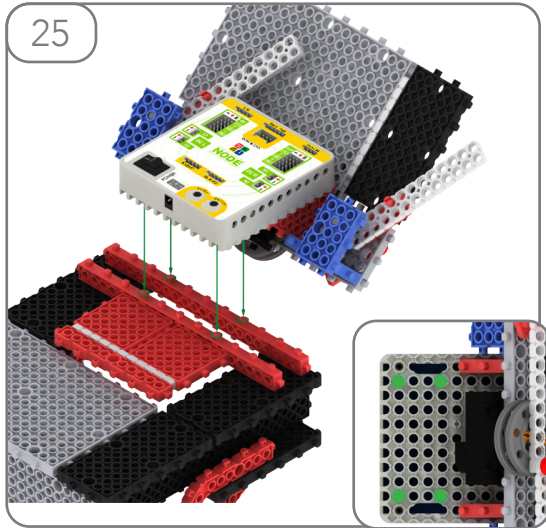

¿Cómo hacer la conexión?

IN1

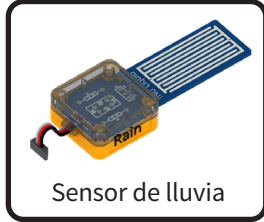

LEFT1

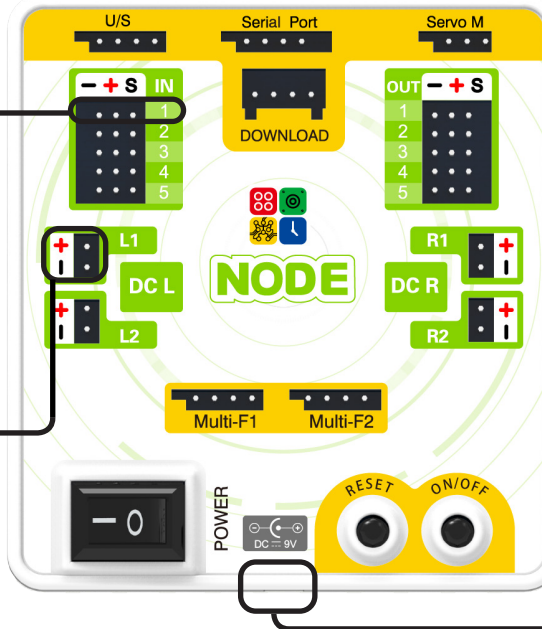
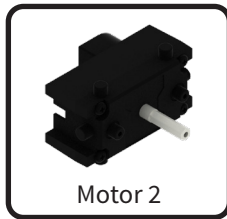

ENERGÍA

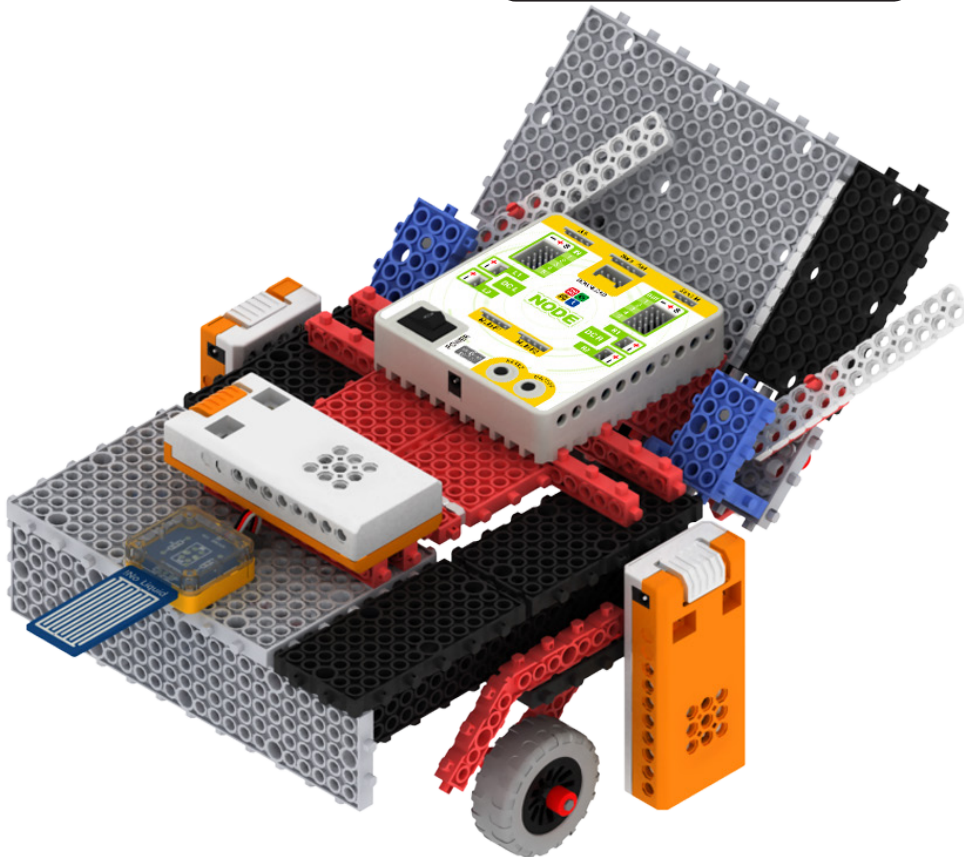
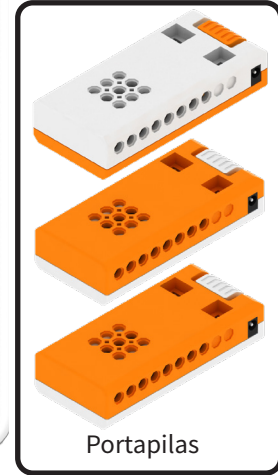

Practica

